

NoTail and Pigtailed Components Faraday Rotator Mirror



The Faraday rotator mirror is a fiber optic polarization rotation mirror designed for fiber optic networks and measurement applications. The state of polarization (SOP) of the reflected light is rotated 90 degrees from that of the input light. A unique property of Faraday rotator mirrors is that at any point along the fiber, the SOPs of the forward going and reflected light are always orthogonal to each other, regardless of the birefringence of the fiber. Therefore, when properly used, the device can help to eliminate polarization sensitivity in optical fiber systems. Applications include eliminating polarization-induced fluctuations in fiber interferometers, Brillouin amplifier systems, fiber laser systems, and fiber optic antenna remoting systems. The FRM's optical path is epoxy free and thus offers low insertion loss and high temperature stability. We also offer the NoTail™ version, which eliminates unwanted optical path delay and pigtail handling problems.

Specifications:

Operating Wavelength	1550 nm, 1310 nm	1064 nm
Operating Bandwidth	±50 nm	±5 nm
Insertion Loss	0.3 dB typical 0.5 dB max.	3.0 dB max.
Faraday Rotation Angle	90 degrees	90 degrees
Rotation Angle Tolerance (Center Wavelength at 23 °C)	±1 degree	±3 degrees
Rotation Angle Wavelength Dependence	±0.12 degree/nm	
Rotation Angle Temperature Dependence	±0.12 degree/°C	PMD: 0.05 ps
Reflection Polarization Dependence	0.5% max.	PDL: 0.05 dB
Optical Power Handling	300 mW min.	150 mW
Operating Temperature	0 to 70 °C	-5 to 50 °C
Storage Temperature	-40 to 85 °C	-40 to 85 °C
Fiber Type	SMF-28	HI 1060 Fiber
Dimensions	Ø 5.5 × 32 mm (pigtailed) Ø 9.5 × 50 mm (NoTail™)	Ø 5.5 × 35 mm (pigtailed)

Note: Values are referenced without connectors

Features:

- Compact size
- Low insertion loss
- High stability
- Rugged design
- NoTail™ model available

Applications:

- Polarization sensitivity elimination in:
 - Fiber interferometers & sensors
 - Fiber laser systems
 - Brillouin amplifiers
 - Fiber optic antenna remoting systems
 - Fiber optic modules

Tech Info: p. 215
App Note: p. 208

NoTail and Pigtailed Components
Faraday Rotator Mirror

Typical Performance Data:

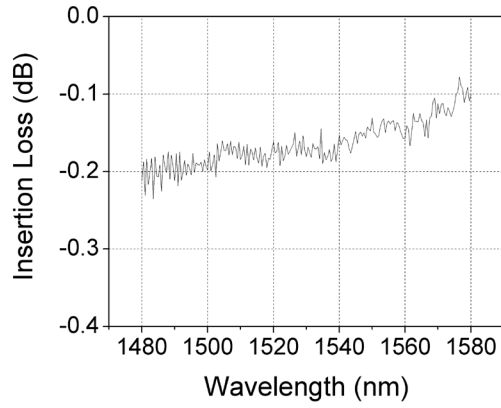
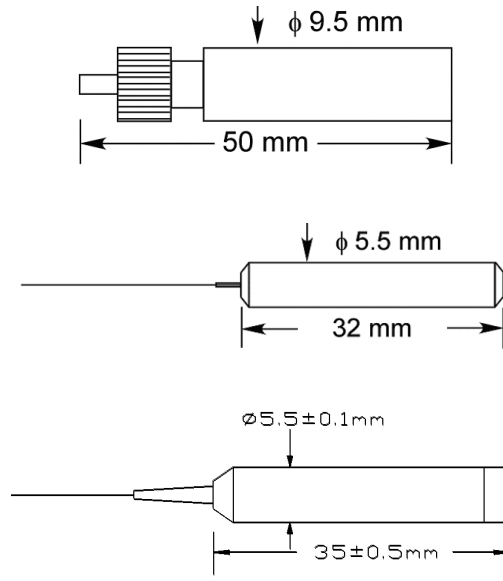

Figure 1. Insertion loss vs. wavelength

Dimensions:



Ordering Information:

Visit our online store at www.generalphotonics.com for detailed configuration information.

INSTRUMENTS

MODULES

OCT PRODUCTS

SPECIAL POLARIZATION COMPONENTS

ACCESSORIES

APPLICATION GUIDE